

H23 TPX H25 TPX

Telescopic booms

The Haulotte® advantages

- Improved working area through a positive / negative articulating fly jib with 140° movement.
- Hydraulic differential lock and 1ft 1in (35 cm) ground clearance for improved rough terrain capability.
- Continuous 360° turntable rotation.
- 180° hydraulic platform rotation.
- Compact travel/transport dimensions.
- Full proportional controls and simultaneous boom functions improve productivity.
- Work platform overload limiter increases safety.
- Robust, reliable and easy to maintain design.

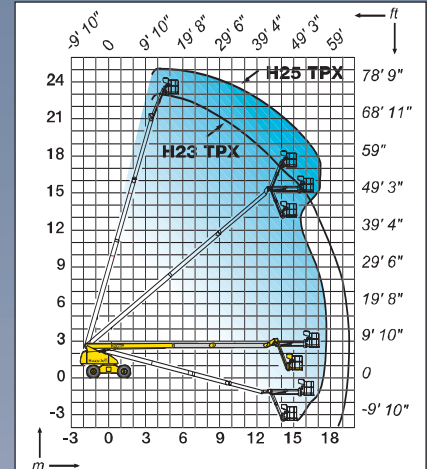
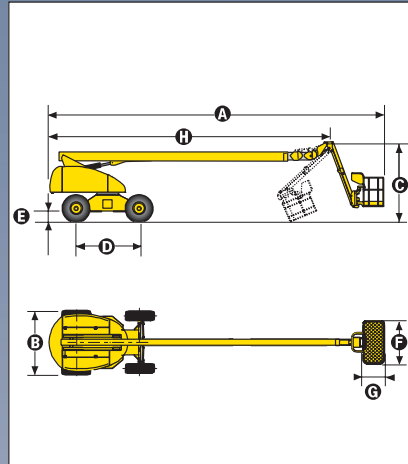

STANDARD FEATURES

- Silent pack Hatz Diesel engine
- 4 wheel drive
- 5° tilt alarm
- 24 V electrical control system
- 12 V - 95 Ah - battery
- Free wheeling device
- Electric emergency lowering system
- Safe use in winds up to 37 mph (60 km/h)
- Hourmeter
- Turret slewing lock rod
- Towing hooks / lifting eyes
- 2 hooks for safety harness in platform

OPTIONS & ACCESSORIES

- Large platform H23TPX (2.3 m x 0.8 m / 7ft 6in x 2ft 7in)
- 220V / 16A power line to platform
- Rotating beacon
- Flashing light
- Travel alarm
- Catalytic exhaust
- Hostile environment kit
- Encoded starting device
- On-board generator 3,3 kW
- Hot countries kit / cold countries kit
- Sand tyres / road tyres

SPECIFICATIONS

	H23TPX		H25TPX	
Working height	74 ft	22,6 m	82 ft 8 in	25,2 m
Platform height	68 ft	20,6 m	76 ft 1 in	23,2 m
Horizontal outreach	64 ft	19,5 m	57 ft 1 in	17,4 m
Platform capacity	550 lb	250 kg	550 lb	250 kg
Fly jib range of motion	140° (-70°/+70°)		140° (-70°/+70°)	
Jib length	7ft 2in	2,2 m	7ft 7in	2,2 m
A Length	34 ft 9 in	10,6 m	42 ft 11 in	13,1 m
B Width	8 ft 1 in	2,47 m	8 ft 2 in	2,48 m
C Stowed height	9 ft 10 in	3 m	9 ft 10 in	3 m
D Wheelbase	8 ft 1 in	2,49 m	8 ft 1 in	2,49 m
E Ground clearance	1 ft 1 in	35 cm	1 ft 1 in	35 cm
F x G Platform size	71 in x 32 in	1,8 m x 0,8 m	71 in x 32 in	1,8 m x 0,8 m
H Travel/transport length	26 ft 6 in	8,1 m	35 ft 4 in	10,8 m
Tailswing	3ft 7 in	1,1 m	3ft 7 in	1,1 m
Drive speed	3.1 mph	5 km/h	3.1 mph	5 km/h
Outside turning radius	21 ft 3 in	6,5 m	21 ft 3 in	6,5 m
Turntable rotation (continuous)	360°	360°	360°	360°
Hydraulic platform rotation	180°	180°	180°	180°
Gradeability	40%	40%	40%	40%
Engine	Diesel Hatz 3 L 41C - 53 hp - 38 kW			
Controls	proportional	proportional	proportional	proportional
Tyres (foram filled)	15 R 22.5 XF	15 R 22.5 XF	15 R 22.5 XF	15 R 22.5 XF
Hydraulic tank	33 gallons	150 l	33 gallons	150 l
Fuel tank	33 gallons	150 l	33 gallons	150 l
Weight	30,071 lb	16.640 kg	30,248 lb	13.720 kg



D I S T R I B U T E D B Y

